

男子個人

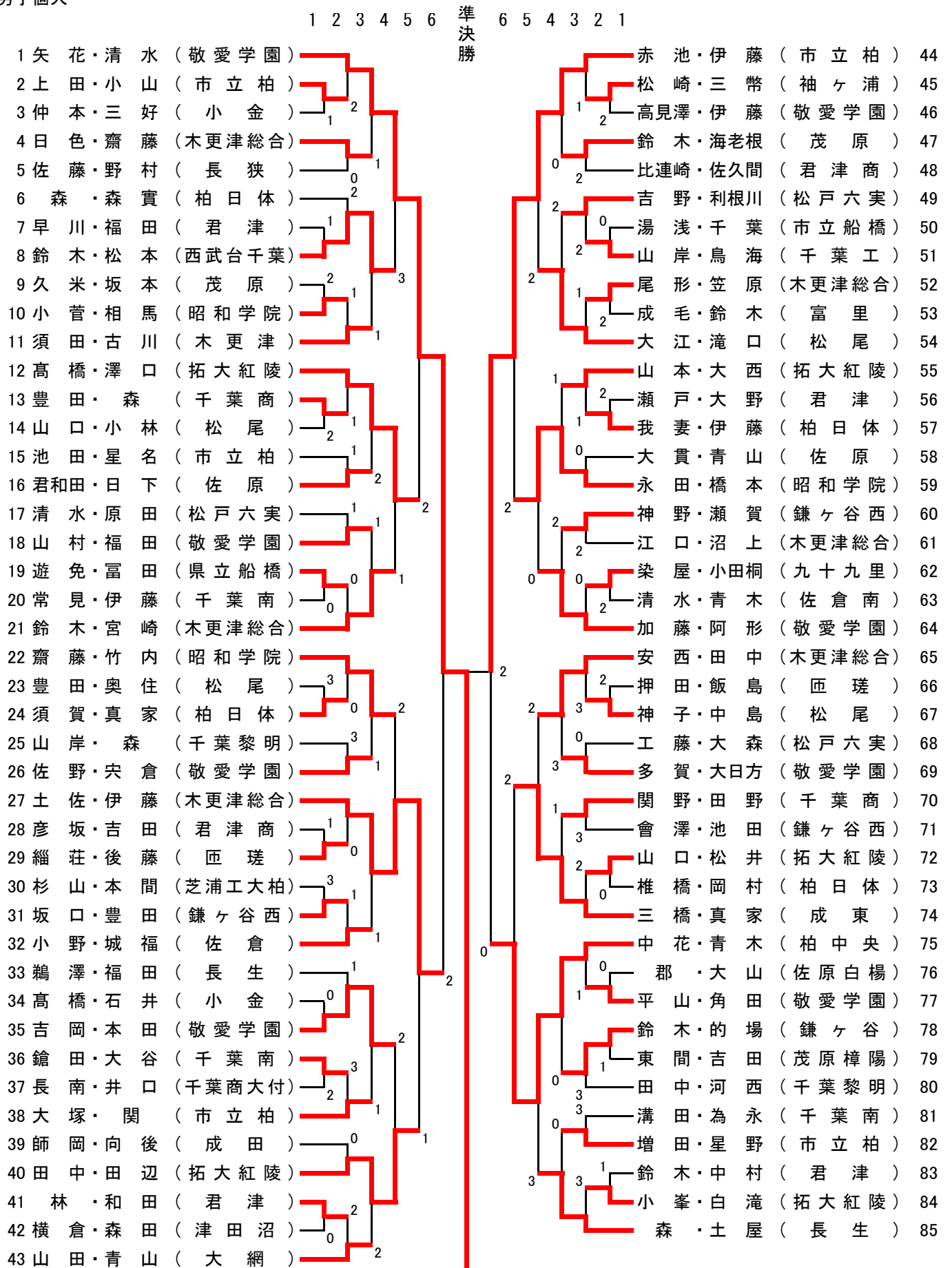

1 2 3 4 5 6 準決勝 6 5 4 3 2 1

